



OUTDOOR DUAL-TECH MOTION DETECTORS

OPAL, OPAL Plus, OPAL Pro, AOD-210



The area around the house
as secure as its interior

Reliable detection



High resistance to adverse weather conditions

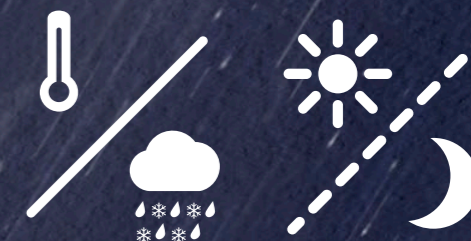

Brackets

Selectable mounting method, thanks to dedicated **angle-type**, **ball-joint type** and **distance-type** holders.

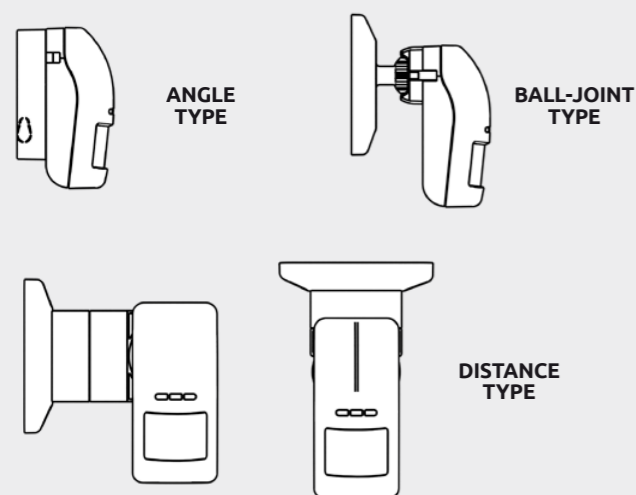

Remote configuration

Easy remote sensitivity configuration of all detection circuits and dusk sensor using OPT-1 keyfob (OPAL Plus/OPAL Pro)



Additional features

Pet immunity up to 20 kg.



The OPAL Pro model meets the EN 50131, Grade 3 requirements, when the detector is used indoors.

Building automation

The OPAL Plus and OPAL Pro models are equipped with a dusk sensor that can be used to implement building automation functions.

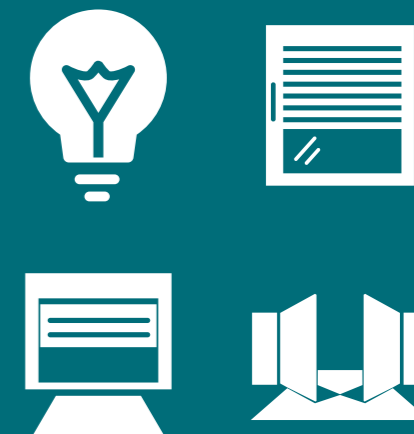

Advanced outdoor detectors

When planning an alarm system, one should not focus solely on detecting the presence of an intruder inside the protected premises. It is equally or perhaps even more important that he be detected before causing any damage to the building. Such an attempt to penetrate the outer zone of protected premises will be detected by the OPAL detectors.

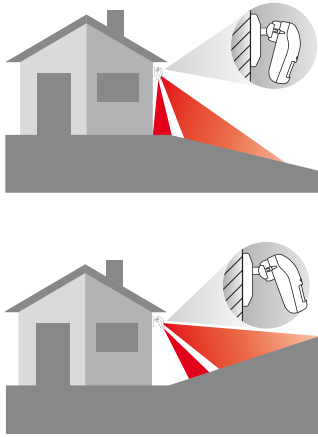

Application

OPAL, OPAL Plus and OPAL Pro provide excellent outdoor protection in buildings of various types and purpose. These devices will also perform very well as the indoor protection in industrial buildings where difficult or specific environmental conditions prevail (in halls, shelters, sheds etc.). The OPAL series detectors can also be used for the implementation of alarm systems with home automation. This is made possible by a dusk sensor with which OPAL Plus and OPAL Pro are fitted. You can directly control the relays located in electrical distribution board or the automation controllers. These detectors can also interface with the KNX system via an INTEGRA series control panel, which allows you to easily and conveniently control the roller shutters, exterior lighting of the building, garage door, entrance gate, etc. The moment of operation can be selected through fine sensitivity adjustment.

Operating range

Detection angle of the OPAL detectors is as high as 100 degrees and their range exceeds 15 m. The creep zone is also protected, so any intruder's attempt to creep up on the device to damage it or tear off the wall will be detected. Additionally, the detector software is designed so as to prevent false alarms from being triggered by the movement of small pets.

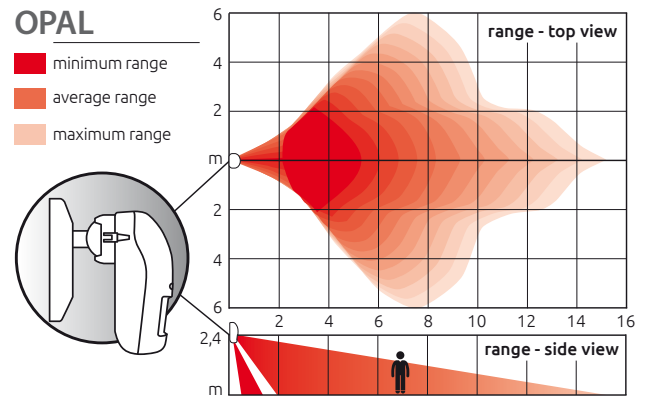

Resistance to weather conditions

The SATEL outdoor detectors offer stable performance regardless of whether they work in rain, in bright sunlight, during strong gusts of wind or in very high or very low temperatures. This functionality is provided by a combination of dual technology of detection and an algorithm of auto-adaptation to environmental conditions with automatic compensation for changes in ambient temperature.

Resistance of the OPAL series detectors to severe weather conditions has been confirmed in comprehensive long-term tests.

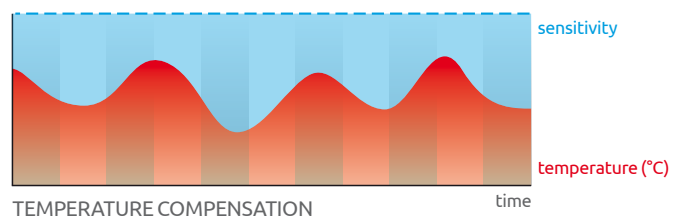

Anti-masking protection

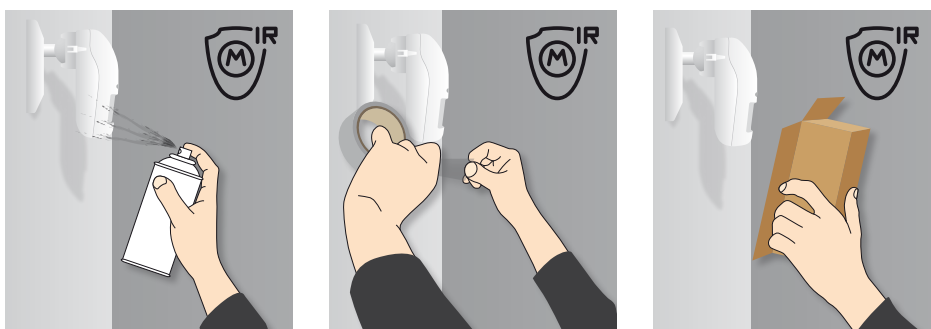

OPAL Pro is provided with an active IR anti-masking function, so it will detect any attempt to cover the detector lens with paint or lacquer, or with materials of different thickness, color and texture.

In OPAL and OPAL Plus, the anti-masking function is implemented in the microwave circuit, which enables detection of objects moving around in close proximity to the detectors.

Detector design

High quality of the detectors of OPAL series results from combining the latest technology and many years' experience of SATEL specialists in the design and production of devices for intrusion and hold-up alarm systems. This is evidenced by the design of detectors, both their electronics and the enclosure itself.



Enclosures of the detectors are made of a combination of polycarbonate and thermoplastic elastomer using two-component injection technology. **The thus obtained design is IP54 rated**, which makes the detectors splash-proof and suitable for outdoor applications as well. The enclosure protects electronic circuits of the device against potentially harmful phenomena, such as rain, snow, fog or moisture. Moreover, the detectors are characterized by a high mechanical strength and resistance to UV radiation, so their appearance remains unchanged for many years.

Useful features and extra components

Remote configuration of sensitivity

A big help for the installer is the ability to remotely change the sensitivity of all detection circuits and dusk sensor in OPAL Plus and OPAL Pro detectors by using the OPT-1 IR keyfob. This feature simplifies control, as it eliminates the need to frequently open the device enclosure to do the job. The CR2032 battery powered keyfob ensures several thousand adjustments.



Mounting methods

Design of the OPAL series detectors enables them to be mounted directly on a flat surface, e.g. when the pet immunity option will be used. If, however, the detector needs to be mounted at another angle for the optimum coverage of the protected area, you can use the BRACKET C or BRACKET E set of dedicated brackets.

The ball-joint bracket, available in BRACKET C and BRACKET E, allows you to swivel the detector in two planes: up to 60° vertically and up to 90° horizontally. This makes it easier to find the optimal position relative to the protected area. However, if the premises require that the detector be set permanently at an angle of 45° relative to the wall, the angle bracket can be used.

The BRACKET E modular holder also allows the detector to be installed at an angle of 90° or be distanced even by over a dozen centimeters from the wall surface - which will prevent limitation of the detection area by: cornice, external blind, cable gutters, lamp, gutter or wall unevenness. This holder also allows the detector to be installed e.g. on a soffit under the eaves of the roof.



Wiring

For the devices to be installed outdoors, it is extremely important that safety and reliability of their operation be guaranteed. Therefore, the above-mentioned brackets are designed so that the cable by which the detector is connected to the control panel is running inside them. As a result, the whole system is both secure and aesthetic.

Protective hood

Where the detector must be additionally protected against weather and soiling, the HOOD C GY protection can be used. Installation of this protective hood is extremely easy – just mount it directly on the detector enclosure with two snap catches, without using any tools at all.

Tamper protection

No matter what type of bracket you are going to use, the OPAL series detectors will always be protected against being opened and torn off the mounting surface. This is possible owing to the two tamper switches located on the PCB and one specially designed tamper contact that can be mounted in the ball-joint bracket or on the detector back wall (if the angle type bracket is used).

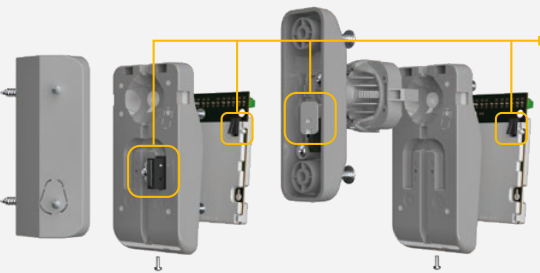

AOD-210 – wireless outdoor protection

Protection can also be provided outside of the building which is to be secured, even where using wired devices is not possible. The AOD-210 outdoor wireless detector, which is designed to work as part of the ABAX 2 two-way system, is ideally suited for such applications.

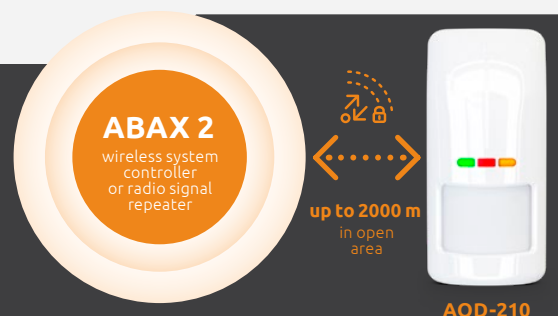

Summary of features and characteristics

	OPAL	OPAL Plus	OPAL Pro	AOD-210
Two detection circuits: PIR+MW	+	+	+	+
Active IR anti-masking according to EN 50131-2-4 for Grade 3	-	-	+*	-
Anti-masking in microwave circuit	+	+	-	-
Built-in dusk sensor enabling the detector to be used in automation systems	-	+	+	+
Built-in receiver of IR OPT-1 keyfob signal	-	+	+	-
Remote sensitivity configuration of detection circuits and dusk sensor with OPT-1 keyfob without having to open detector enclosure	-	+	+	-
Sensitivity configuration of dusk sensor by using PCB located buttons	-	+	+	-
Sensitivity configuration of detection circuits by using PCB buttons	+	+	+	-
Remote sensitivity configuration of detection circuits and dusk sensor from DLOADX or ABAX 2 Soft	-	-	-	+
Reinforced polycarbonate enclosure	+	+	+	+
Splash-proof enclosure, IP54 rated	+	+	+	+
Digital temperature compensation	+	+	+	+
Auto-tuning algorithm for high immunity to false alarms	+	+	+	+
Ability to work in adverse weather conditions (rain, snow, fog, strong wind)	+	+	+	+
Tamper protection (against opening and removal)	+	+	+	+
Low current consumption	+	+	+	+
Dedicated angle-type bracket (45°)	+	+	+	+
Dedicated ball-joint bracket (tilting up to 60° vertically and up to 90° horizontally)	+	+	+	+
Can be mounted on the BRACKET E modular distance holder	+	+	+	+
Dedicated protective hood	+	+	+	+
Wires running inside the bracket for better protection	+	+	+	+
Optional installation without any additional bracket	+	+	+	+
White enclosure <input type="button" value="front"/> <input type="button" value="back"/>	+	+	+	+
Grey enclosure <input type="button" value="front"/> <input type="button" value="back"/>	+	+	+	+
Dark grey accessory enclosure <input type="button" value="front"/> <input type="button" value="back"/>	+	+	-	+

* for indoor applications

Technical parameters

	OPAL	OPAL Plus	OPAL Pro	AOD-210
Environmental class	III A	III A	III A	III A
Security rating	acc. to Grade 2	acc. to Grade 2	acc. to Grade 3*	acc. to Grade 2
Enclosure dimensions	65 x 138 x 58 mm	65 x 138 x 58 mm	65 x 138 x 58 mm	65 x 138 x 58 mm
Operating temperature range	from -40°C to +55°C	from -40°C to +55°C	from -40°C to +55°C	from -40°C to +55°C
Recommended installation height	2,4 m	2,4 m	2,4 m	2,4 m
Standby current consumption	12 mA	15 mA	17 mA	75 µA
Maximum current consumption	20 mA	20 mA	30 mA	30 mA
Operating range	15 m	15 m	15 m	16 m

* for indoor applications

The offer includes products and accessories in three colour versions: white, grey (GY) and dark grey (DG)



OPAL
OPAL GY
OPAL Plus
OPAL Plus GY
OPAL Pro
OPAL Pro GY
AOD-210
AOD-210 GY
Outdoor
PIR+MW
dual-tech
motion
detector

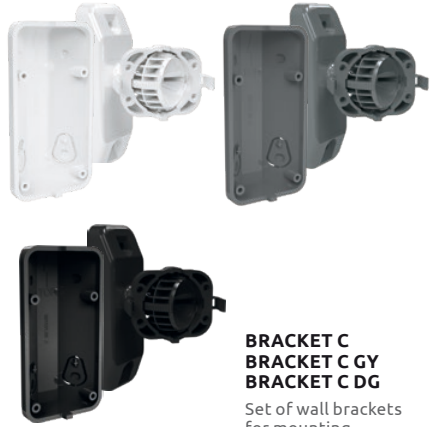

BRACKET C
BRACKET C GY
BRACKET C DG
Set of wall brackets
for mounting
outdoor detectors



BRACKET E
BRACKET E GY
Modular distance holder



HOOD C
HOOD C GY
HOOD C DG
Dedicated
protective hood
for OPAL-series
and AOD-210
motion
detectors



OPC-3 DG
Enclosure
For OPAL,
OPAL Plus
and AOD-210
motion detectors
(dark grey)



ul. Budowlanych 66, 80-298 Gdansk, Poland
tel. +48 58 320 94 00; fax + 48 58 320 94 01
e-mail: trade@satel.pl

www.satel.pl

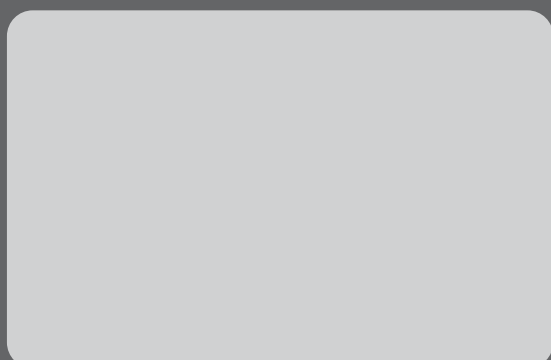

The manufacturer reserves the right to change the specification and technical data of devices.
Images shown are for general information only and may differ from actual products.
U-OPAL-EN0226

35 YEARS OF EXPERIENCE

Professional protection of all type of premises, as well as people staying therein, through advanced, yet functional and cost-effective solutions – these few words may serve as the shortest description of the mission of SATEL, a manufacturer of security systems with involvement of 100% Polish capital. Due to integrity in business and a special emphasis on high quality and a wide range of products offered, the SATEL brand has been highly appreciated in the industry for 35 years.

This philosophy of management and hard work of more than 360 SATEL employees produce tangible results. The wide range of over 450 offered products provides countless opportunities to create security, home automation, fire alarm, access control and event monitoring systems, tailored to the individual needs of each user. At the same time, these systems meet all requirements specified by Polish and international regulations and industry standards.

Bringing the functionality of devices into line with current requirements and expectations of the market with the use of the latest technologies is one of the main objectives of SATEL. For this reason the design and production departments of the Company are continuously being modernized and expanded. A natural consequence of all actions aimed at the production of top-quality devices was the introduction of the quality management system conforming to ISO 9001:2000 in 2002. Regardless of this certification, SATEL also carries out a full functional test of all products leaving the production line, thus ensuring reliability of the manufactured devices. Focusing on modern design and attaching importance to the highest levels of quality and functionality of its products, SATEL has gained many satisfied customers not only in Poland but also in more than 70 markets worldwide.